



Model

MP40

Product Description

Planetary Mixer, 40 litre, Heavy Duty

Product Code

5MP40-1PH

5MP40-3PH

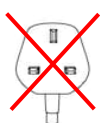

Standard Features

- Heavy duty 40ltr, floor standing, gear driven, planetary mixer
- Particularly suitable for bakeries, hotels, restaurants, canteens etc
- Easy to operate
- Planetary mixing action ensures perfect results
- High torque motor allows mixing of stiffer doughs and larger batches
- 3 fixed speeds: 95, 195 and 356 rpm
- Easy speed-shifting
- Timer
- Emergency stop button
- Interlocking bowl guard and bowl lift
- Dual bowl clamps to lock bowl down
- Stainless steel safety guard with ingredient chute and automatic shut-off when guard is opened at any speed
- Resettable thermal overload protection (NVR device)
- Long lasting lubricant providing abrasion resistant transmission
- Transmission gears are made of heat treated, hardened steel
- Heavy duty, cast iron frame
- Non-slip rubber feet
- Quiet operation
- Heavy duty gearbox
- Industry standard #12 attachment hub

Standard Accessories / Attachments

- 1 x Whisk
- 1 x Beater
- 1 x Dough Hook
- 1 x 40 litre Stainless steel bowl

Warranty

Covered by Metcalfe 3-year warranty (1st year parts and labour, 2nd & 3rd years parts only) and full after sales service

Optional Accessories / Attachments

Item	Product Code
Bowl	MP11040-12-001
Beater	MP11040-12-002

Item	Product Code
Dough Hook	MP11040-12-003
Whisk	MP11040-12-004

Item	Product Code
20ltr reduction bowl	MP11040-12-001M
20ltr reduction beater	MP11040-12-002M
20ltr reduction dough hook	MP11040-12-003M
20ltr reduction whisk	MP11040-12-004M

Item	Product Code
Bowl Trolley	MP11040-12-011
Meat Mincer Attachment	MPG12SH
Veg Prep Attachment	MPVS12A

Drawing

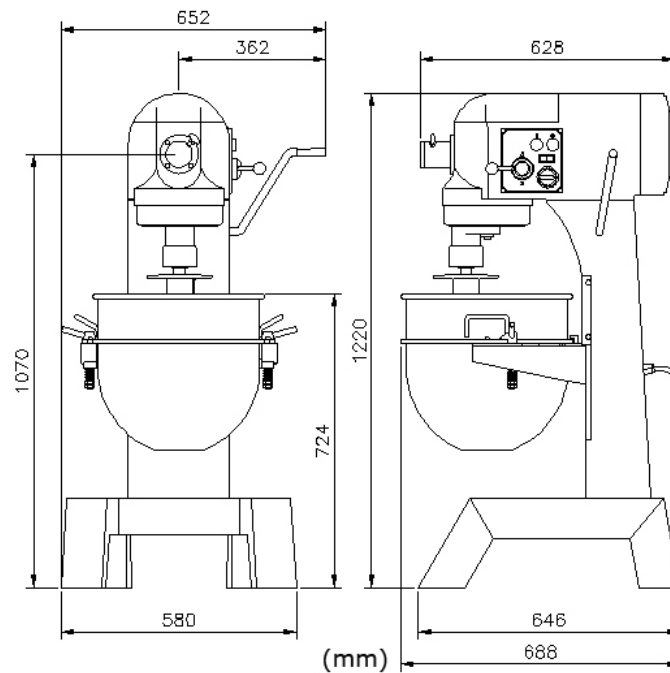

Specifications

Model	Capacity (ltr)	Phase (Ø)	Motor (Volt)	Frequency (Hz)	Power (kW) / (hp)	Speed (rpm)
MP40-1ph	40	1	220-240	50	1.125 / 1.5	95 / 195 / 356
MP40-3ph	40	3	380-415	50	1.125 / 1.5	95 / 195 / 356

Dimensions | Shipping Information

Model	Overall Dimensions D x W x H (mm)	Net Weight (kg)	Packed Dimensions D x W x H (mm)	Packed Weight (kg)	Volume (m3)
MP40	688 x 652 x 1220	205	820 x 720 x 1430	217	0.844

We reserve the right to alter the specification and technical details for this item at any time without prior notice. 05/2021

Metcalfe Catering Equipment Ltd

Haygarth Park
Blaenau Ffestiniog
Gwynedd, LL41 3PF

